



Kardeşler Makina A.Ş.

Address :Rami Yolu Kışla Cad. Başaran San. Sit.
No:111/116 Topçular / ISTANBUL
Phone : +90(212) 544 3733 - 612 6216 - 565 7926
Fax : +90(212) 501 7023
e-mail : info@kardeslermakina.com.tr
Url : www.kardeslermakina.com.tr

📄 BTA - 3000

📄 DRAWING

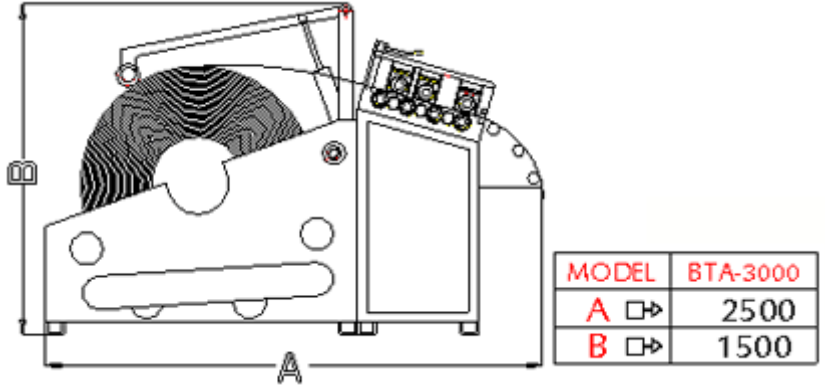

📄 PRODUCT PROPERTIES

▶Max Roll Weigth	3000Kg
▶Max Roll Width	400mm
▶Max Roll External Diameter	1000mm
▶Min / Max Band Thickness	1 - 3mm
▶Roll Handling System	Cradle Type
▶Metal Sheet Width Adjustment System	Mechanic
▶Metal Sheet Width Min / Max	20-400mm
▶Drive Type	AC Engine Redactor
▶Engine	1,5 Kw
▶Power Source	380V
▶Max Discharge Velocity	10mt/dk

Drawing & Rectifying Unit

▶Max Band Width	400mm
▶Min / Max Band Thickness	1 - 3mm
▶Type Of Material	4140
▶Max Tape Cutting Area	1200mm ²
▶Rectifying Rollers, X Diameter	5x60mm
▶Drawing Rollers, X Diameter	2x60mm
▶Oscillating Direction Pulleys	5x30mm