



Kardeşler Makina A.Ş.

Address : Rami Yolu Kışla Cad. Başaran San. Sit.
No:111/116 Topçular / ISTANBUL
Phone : +90(212) 544 3733 - 612 6216 - 565 7926
Fax : +90(212) 501 7023
e-mail : info@kardeslermakina.com.tr
Url : www.kardeslermakina.com.tr

CFDRA - 800

DRAWING

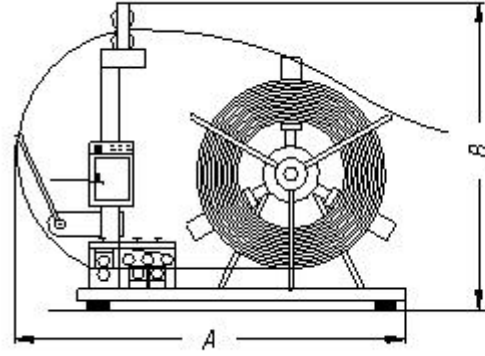

MODEL	CFDRA-800
A	2000
B	1500

PRODUCT PROPERTIES

▶Max Roll Weigth	800 Kg
▶Max Roll Width	250mm
▶Max Roll External Diameter	1200mm
▶Min/ Max Band Thickness	0,1 - 3mm
▶Max Roll External Diameter	300 - 600mm
▶Roll Handling System	Internal compressed pulley
▶Arm Turn-On/Turn Off System	Mechanic

Drawing & Rectifying Unit

▶Max Band Width	250mm
▶Min/ Max Band Thickness	0,5 - 3mm
▶Material Type Fabrication Steel	1050
▶Max Band Cross-Section Area	750mm ²
▶Material Cross-Section	250 x 2,5mm
▶Quantity of Rectifying Roller X diameter	5x47mm
▶Quantity of Drawing Roller X diameter	2x58mm
▶Max Discharge Velocity	16mt/mn
▶Dc Velocity Control Panel	220V
▶Drive Type	AC engine redactor